

# 832 Series

## *Sulfur/Carbon Analysis by Combustion*



**LECO**  
EMPOWERING RESULTS

# 832 Series: Sulfur/Carbon Analysis by Combustion

LECO's 832 Series redefines the way you determine carbon and sulfur in coal, coke, cement, soil, fuel oils, and other organic materials. Using extensive customer feedback and innovative engineering, our latest instrumentation takes advantage of an on-board software platform powered by a touch-screen interface, increasing usability and operational control without using valuable bench space.

Additional features—such as a high-efficiency combustion furnace, improved IR cell design, and a robust, rugged design—make the 832 a valuable resource for any laboratory needing fast and accurate analysis of sulfur and/or carbon in organic materials.



# User-Friendly Cornerstone Brand Software

LECO's exclusive Cornerstone brand software with touch interface enables the user to have complete access to analysis control, method settings, diagnostics, reporting, and more in a highly organized and immersive environment. Designed through a collaboration of customer feedback and innovative engineering, Cornerstone allows the user to conduct all of their day-to-day operations within a single analysis screen designed for speed and ease of use. Our innovative grouping of sample data into sets and replicates simplifies the data output and automatically calculates relevant statistics, alleviating the need for additional data processing.

The screenshot displays the LECO Cornerstone software interface, which is organized into several functional areas:

- Navigation Bar:** Includes 'Cornerstone\* Guide Help' and a date/time stamp '9/15/2022 4:32:35 PM'. Below this are tabs for 'ANALYSIS', 'DIAGNOSTICS', 'SETTINGS', and 'INSTRUMENT'.
- Control Panel:** Features icons for 'Blank', 'Drift', 'Calibrate', 'Recalc', 'Include', 'Exclude', 'Delete', 'Output', 'Import', 'Next', 'Pause', and 'Notify'.
- Table:** A table with columns for 'NAME', 'DESCRIPTION', 'METHOD', 'SULFUR AVERAGE', 'CARBON AVERAGE', and 'ANALYSIS DATE'. It lists various samples, including blanks and replicates, with their respective analysis results.
- Summary Section:** Displays '1 Selected' and '1 Replicates'. It includes buttons for 'Blank', 'Standard', 'Drift', 'Sample', and 'Template'.
- Graphs:** Two graphs are shown. The left graph is for Sulfur, showing a peak at approximately 55 minutes with a value of  $0.970 \pm 0.00787$  (n=3, RSD%=0.811). The right graph is for Carbon, showing a peak at approximately 85 minutes with a value of  $0.990 \pm 0.00360$  (n=3, RSD%=0.363).
- Instrument Status:** A row of four gauges showing 'FURNACE TEMPERATURE' (1350.0 °C), 'INCOMING PRESSURE' (16 psi), 'PUMP PRESSURE' (29.8 psi), and 'BACK PRESSURE' (800 mmHg).
- Controls:** Includes 'Gas' (Off/On), 'Furnace' (Standby/Operating), and an 'Abort' button.
- LECO Logo:** A large circular logo with the text 'LECO' inside.
- Status Bar:** At the bottom, it says 'Ready To Analyze.' and includes a notification bell icon.

Analysis

## Software Features & Benefits

The software is divided into four main sections—Analysis, Diagnostics, Settings, and Instrument—for simplified navigation and organization. Toolbars, sliders, and drop-down menus make it easy to set parameters for calibration and data processing. The software also includes real-time monitoring of ambient parameters, with fully animated system diagrams.

Advanced interactive diagnostic features include a thorough digital on-board manual, maintenance animations, photo illustrations, and screen captures that quickly provide the direction needed without having to refer to multiple manuals.

Cornerstone also supports a multilingual interface, user permissions, extended data archiving and filtering, compatibility with various Laboratory Information Management Systems (LIMS), and flexible reporting capabilities.



Diagnostics > Ambients



Instrument > Furnace



Settings > Calibration

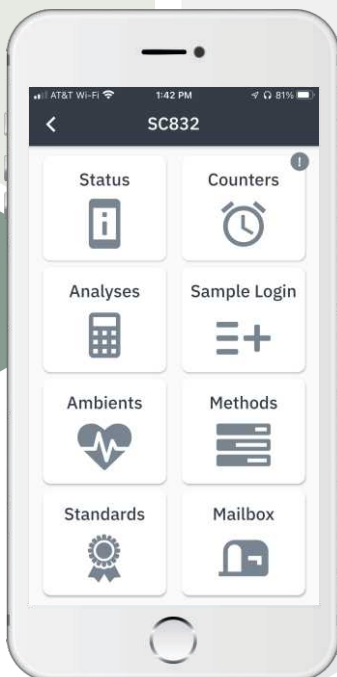

An optional Cornerstone Mobile application feature enables remote viewing of the instrument software from a smartphone, tablet, or PC. It can also be programmed to set automatic notifications from the instrument against predefined software conditions using e-mail, text message, or the Cornerstone Mobile application.

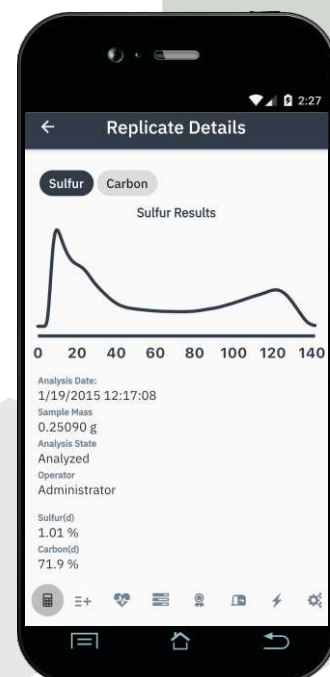

## Instrument Highlights and Features

### High-Efficiency Furnace System Design

- Lower electrical requirement resulting in lower operating costs
- Intelligent furnace control optimizes furnace reliability and extends the heating element and ceramics lifetime
- Horizontal high temperature (up to 1550 °C with optional HT model) concentric ceramic furnace tube with ceramic lance directing oxygen directly onto the sample ensuring rapid analysis times, complete combustion, and recovery
- Improved gas flow control reduces ash debris restrictions, increases furnace lifetime, and instrument reliability
- Modified combustion assembly provides furnace isolation from the atmosphere, resulting in low blank value and improved precision

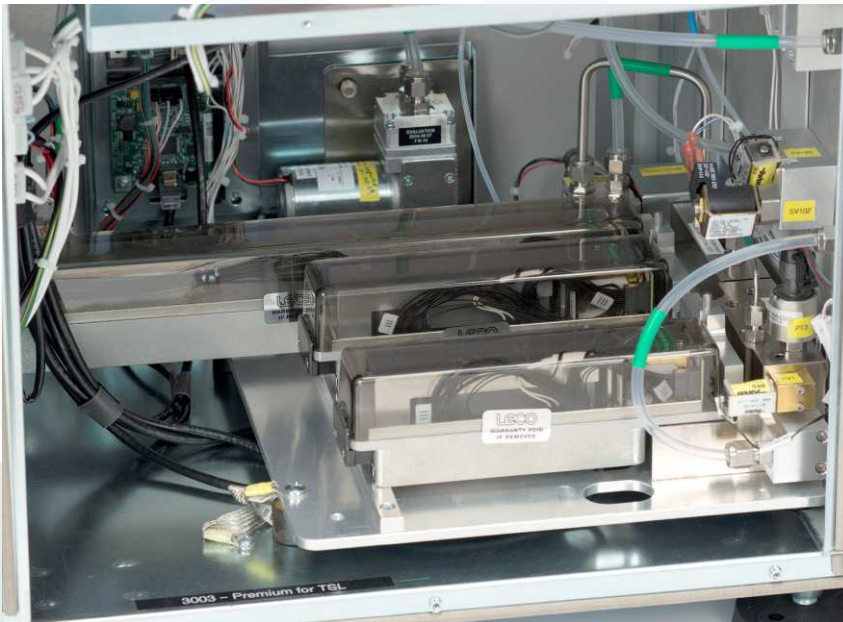
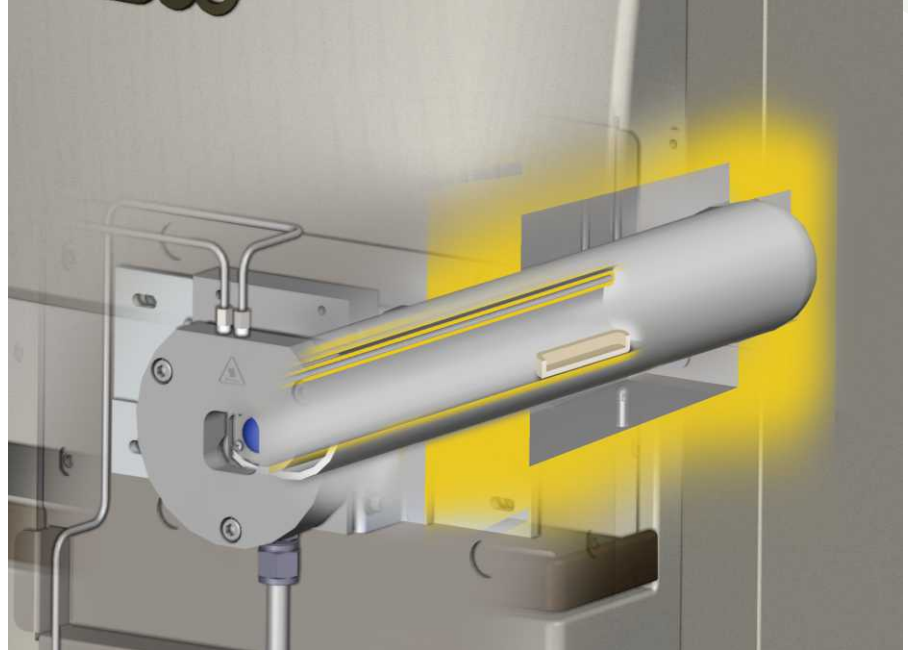

### Improved Solid-State IR Cell Design

- Temperature stabilized construction provides increased isolation from ambient temperature fluctuations and other environmental susceptibilities
- Optimized emitter control and detection circuitry improves the IR cell lifetime and long-term stability, resulting in superior accuracy and precision
- Individual wide-range IR detection for both carbon and sulfur simplifies set-up and calibration for the standard S/C/SC832 models
- Optional dual-range (DR) detection for sulfur within S/SC832DR models have the widest sulfur range capability for the most demanding applications

## Improved Design and Accessibility for Maintenance Areas

- To enhance safety and convenience, the dual reagent tubes and rotameters are located on the front side of the instrument behind the hinged front cabinet door
- Open internal cabinet access to pump with quick release features enables fast and simple preventive maintenance routines, ensuring a robust and reliable instrument with superior uptime
- Top-mounted heating element assemblies result in simple and fast access, and allow for single element replacement when needed, lowering maintenance costs



## Additional Features and Benefits

- Optional Autoloader (L) with 100-sample capacity simplifies operator workflow and increases productivity
- Optional High Temperature (HT) model supports furnace temperatures up to 1550 °C, eliminating the need for combustion accelerators for refractory sample analysis
- Optional boom-mounted touch-screen interface package (M) promotes an ergonomic workspace while reducing system bench space requirements
- Optional Performance Package (P) adds an instrument leak check feature, which provides a valuable diagnostic tool and increases the reliability of the system; and an electronic back pressure control, which provides isolation to changes in atmospheric pressure and results in improved long-term stability
- Dual range (DR) S/SC832DR models contain the performance package features

## Models

S832	Sulfur Determinator
C832	Carbon Determinator
SC832	Sulfur and Carbon Determinator
S832DR	Dual Range Sulfur Determinator
SC832DR	Dual Range Sulfur with Carbon Determinator
S832HT	High Temperature Dual Range Sulfur with Carbon Determinator
SC832HT	High Temperature Dual Range Sulfur with Carbon Determinator

## Options

Monitor (M)	Instrument mounted touch-screen and six-axis boom mount
Performance Pack (P)	Adds an instrument leak check and electronic back pressure control (All DR instrument models contain performance pack)
Autoloader (L)	100-capacity sample Autoloader

NOTE: Multiple configurations of options are available. Please contact your local LECO Sales Engineer for more details.

## LECO—Your source for total analytical solutions



### TGA801 Thermogravimetric Analyzer

- Determines moisture and ash or other gravimetric methods in various organic samples
- Expanded temperature control (up to 1000 °C) with variable atmospheres and ramp rates
- Automated batch thermogravimetric analysis of up to 19 samples

### AC Series Isoperibol Calorimeters

- Accurate calorific measurements
- Ergonomic water-measuring/combustion vessel-filling station
- Analysis time in as little as five minutes
- Meets or exceeds ASTM requirements
- 6,000 to 15,000 Btu/lb for 1 gram sample



Supplies for Organic Analysis



### Organic Consumables

Get the best results from your LECO instrument by using genuine LECO consumables. Visit [www.leco.com](http://www.leco.com) for featured items, specials, and ordering information (Form number 203-828).

*LECO, Cornerstone are registered trademarks of LECO Corporation.*

3000 Lakeview Avenue | St. Joseph, MI 49085 | 800-292-6141 | Phone: 269-985-5496  
info@leco.com | www.leco.com | ISO-9001:2015 Certified | LECO is a registered trademark of LECO Corporation.

**LECO Corporation**



EMPOWERING RESULTS

© 2022 LECO Corporation

Form No. 209-244

10/22-REV3